



Continental APAC Product
and Service Capabilities.

One Source, Many Solutions



Continental Conveying Solutions

We are the leading expert for conveyor belt solutions offering customers worldwide the most complete and advanced product, technology and service portfolio for industry and mining applications. We support our customers, partners, and distributors with a growing range of value-added services along the entire lifetime of a conveyor belt operation, from planning and commissioning, to technical advice, training, digital monitoring, and on-site maintenance. Our cost-effective, sustainable, safe and innovative conveying solutions reduce down times through state of the art condition monitoring and predictive maintenance practises.

We support mining, construction and plant engineering projects around the world as development partner.

Customers benefit from an experience of more than 140 years in high-performance conveyor belts. A network of 1,300 experienced service technicians covers key regions including Africa, Asia, Australia, Europe, North America, and Latin America. With this unique expertise and global footprint, Continental is close to its customers providing not only high-quality, long-life products, but also comprehensive support and service - tailored to customers' specific needs and requirements.

Continental understand the critical role that conveyor components play in customers productivity. Our range of diverse, innovative conveyor components are designed to optimize your conveyor systems reliability and performance.

The recommended product solution will only work as well as it is installed and maintained. We support this initiative by offering the expertise of our services division, where specialist mechanical trades people take complete ownership for the installation and ongoing maintenance of the product.

We are your conveyor system solution provider

We support you in getting your conveyor system up and running through the supply of various mandatory components and related services for improved conveyor system productivity. The portfolio is completed by a comprehensive range of services to meet your individual needs and makes us your global partner when it comes to conveyor systems component supply, operations and maintenance support.

For more detailed information, please scan the QR code below or contact your local Continental Service contact.



or contact your local Continental Service Contact.





Table of Contents

Service Materials

Splice Materials.....	6
Adhesives, Solutions, and Solvents.....	6
Maintenance Repair Materials.....	6

Tools & Equipment

Tools & Equipment.....	7
------------------------	---

Accessories & Components

Belt Cleaners Systems.....	8
Belt Trackers.....	9
Skirt Systems & Accessories.....	10
Rollers & Frames.....	11
Conveyor Pulleys.....	12
Conveyor Pulley Lagging.....	13

Digital Solutions

Conveyor Condition Monitoring Software.....	14
Belt Monitoring Systems.....	15

Service Engineering

Service Engineering.....	16
--------------------------	----

Field Services

Field Services.....	17
---------------------	----

Service Materials

Continental offers engineered solutions for high performance Splice Materials; adhesives, Solutions (splice cement), and Solvents; and Maintenance Repair Materials. These products provide dynamically tested and well proven solutions for even the most aggressive applications.

Service Materials

Splice Materials

- > All rubbers, fabrics, cements, and solvents needed for a high-performance splice
- > Cover rubbers and inside rubbers designed to provide the best dynamic performance in the industry for general purpose, underground, and specialty compounds
- > Preform Splice Kits
- > Traditional Splice Kits

Adhesives, Solutions, and Solvents

- > Cold Bond Adhesives
- > Hot Bond Rubber Solutions (cements)
- > Cleaning Solvents

Maintenance Repair Materials

- > Two-Component Polyurethane belt repair paste - fast setting, high-performance
- > Belt Repair Strips

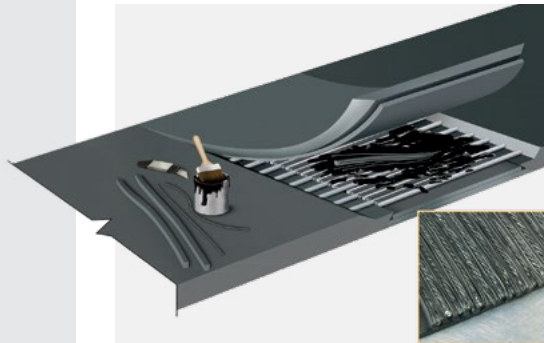

Tools & Equipment

Continental offers a wide range of Tools, needed for Belt Splicing and Repairs.

Tools & Equipment

- > General hand-held tools for all purposes
- > Measurement tools - used to determine geometric and physical data
- > Cutting tools - for splicing, installing and repairing conveyor belts
- > Pulling Plates

NOTE: Availability of hand tools is subject to supply.



Accessories & Components

Continental Conveyor Accessories and Components supports the correct product selection for your specific application. Continental strives to offer a comprehensive range of products to optimise conveyor productivity.

Belt Cleaning Systems

All components are manufactured from high quality stainless steel. Available in Standard and Heavy Duty construction. All products are designed to optimise cleaning efficiency.

> Primary Cleaners

- Tungsten Tips
- Polyurethane Blades
- FRAS Polyurethane Blades
- Reinforced Poles
- Retractable Configuration
- Component Spares

> Secondary Belt Cleaners

- Single and Bi-Directional
- Tungsten Tips
- Reinforced Poles
- Retractable Configuration
- Spray Pole Systems
- Water Control Assemblies
- Component Spares

> Plough Cleaners

- Floating Vee Plough
- Failsafe Vee Plough
- Torsion Vee Plough
- Diagonal Plough - Single Direction
- Diagonal Plough - Reversing
- Polyurethane Blades
- FRAS Polyurethane Blades
- Component Spares

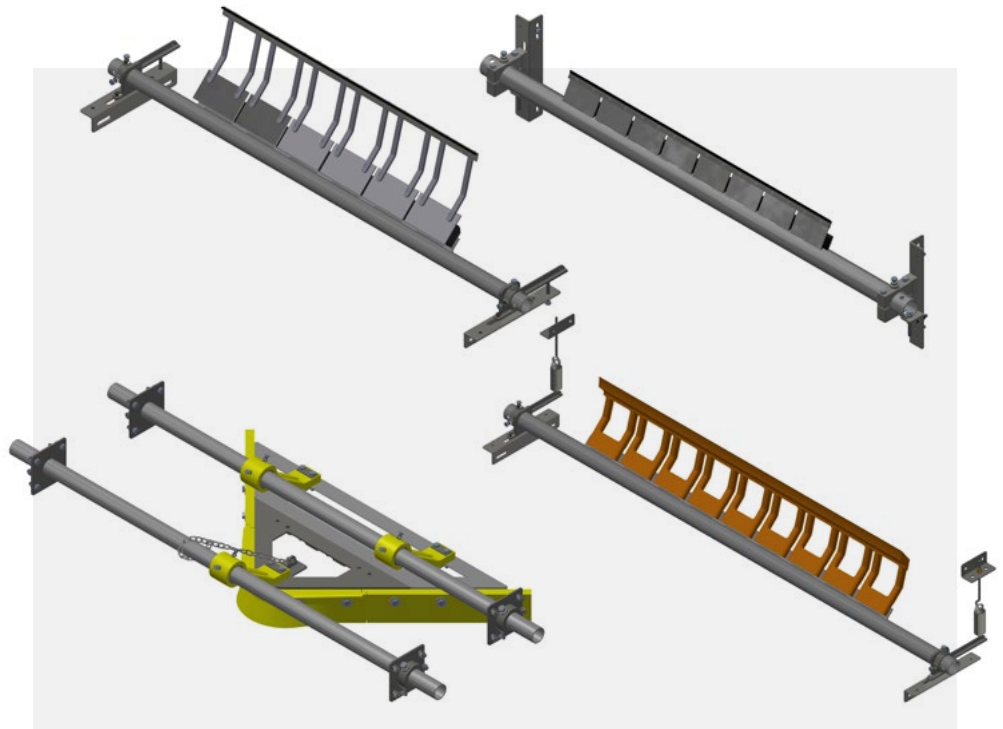

Belt Trackers

All components are manufactured from high quality stainless steel. Available in Standard, Heavy Duty and EHD construction.

- > Stainless Steel Construction
- > Standard, Heavy Duty & EHD Design
- > 1 Roll Flat Return Tracker
- > 2 Roll Vee Return Tracker
- > 3 Roll Trough Tracker
- > Inverted Vee Tracker

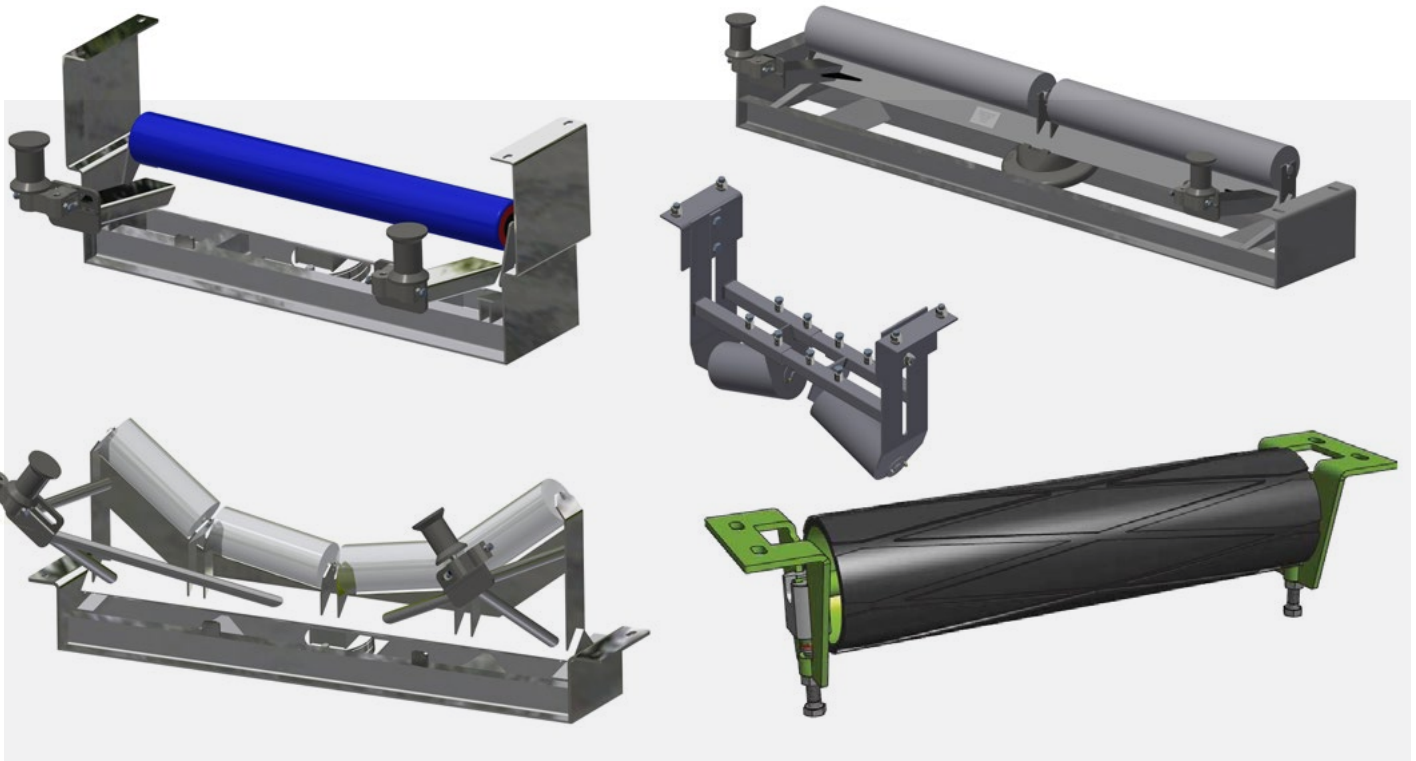

Skirt Systems & Accessories

All components are manufactured from high quality stainless steel. The design configuration allows for fully customizable and adjustable configuration.

- > Stainless Steel Construction
- > Screw Lock Clamp Design
- > Fully Adjustable Configuration
- > Rubber Skirting Materials
- > Polyurethane Skirting Materials
- > Belt Cleaner Blades, Tips and Cushions
- > Inspection Hatches
- > Water Spray Pole Systems and Fittings
- > Air Pressure Control Boxes and Fittings
- > Hold Down Rollers



Rollers & Frames

Quality manufacturing of high end steel rollers and frames combined with the most modern polymer technology allows Continental to offer a comprehensive and innovative range of roller and frame products.

- > Steel Rollers
- > Hybrid Rollers
- > Composite Rollers
- > Aluminum Rollers
- > Rubber/PU Coated Rollers
- > Impact/Segmented Disc Rollers
- > Specialty Rollers
- > Garlands
- > Trough Frames
- > Return Frames
- > Impact Frames
- > Retractable Frames
- > Pressure Roller Mounting Kit
- > Stabilizing Roller Mounting Kit
- > Spares



Conveyor Pulleys

A vast array of pulley designs are available to suit your specific applications. Engineering support available for accurate pulley selection, duty and design.

- > Standard Duty Drum Pulley
- > Quarry Duty Drum Pulley
- > Mine Duty Drum Pulley
- > Engineered Class Drum Pulley
- > Machined Drum Pulley
- > Clean Flight Wing Pulleys

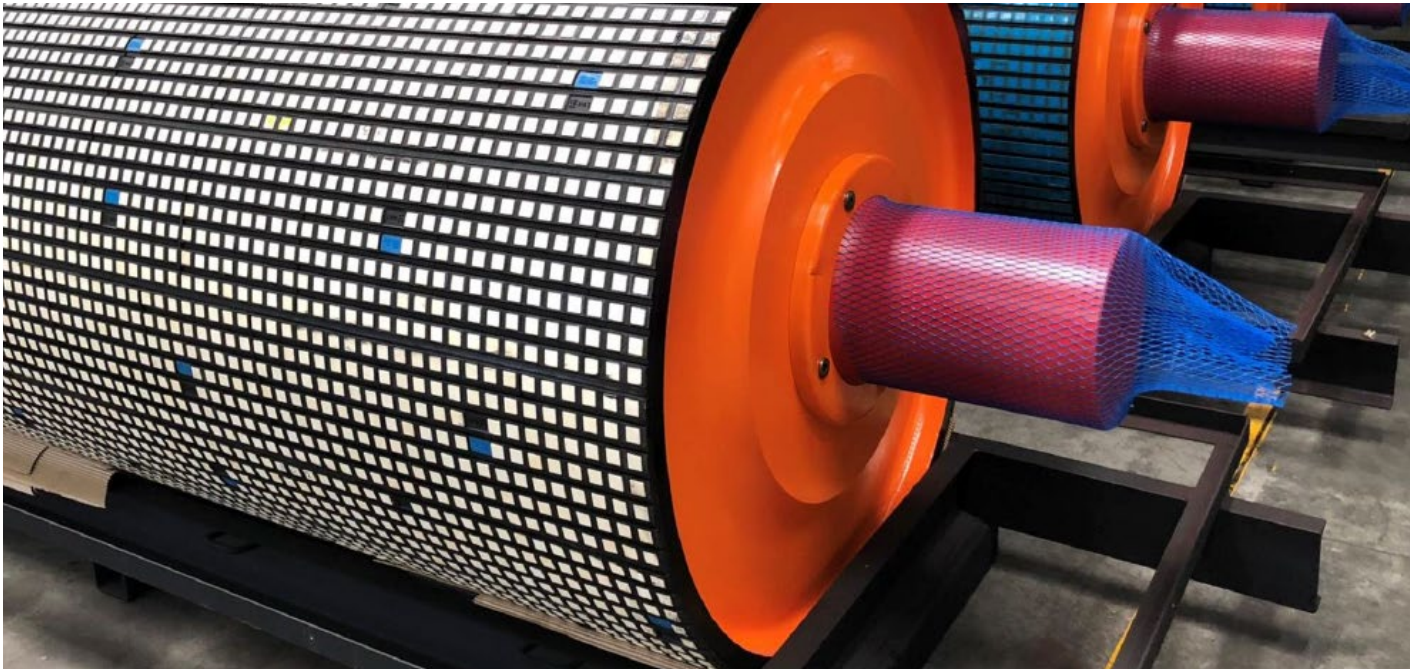

Conveyor Pulley Lagging

Flexible and high abrasion resistant lagging for all drive and non-drive applications. Engineered solutions available for specific lagging selection. Hot or Cold Vulcanized options available. All base rubber materials available in a range of thicknesses. FRAS lagging available.

- > Rubber Lagging
- > Rubber Wear Indicator Lagging
- > Rubber Slide Lagging
- > Rubber Crowned Lagging
- > High Tension Bend/ Extreme Rubber Lagging
- > Ceramic Lagging (80%, 38%, 20%, 15% Tile coverage)
- > Extreme Ceramic Lagging - High Tension Applications
- > Direct Bond Ceramic Lagging
- > Polyurethane Lagging

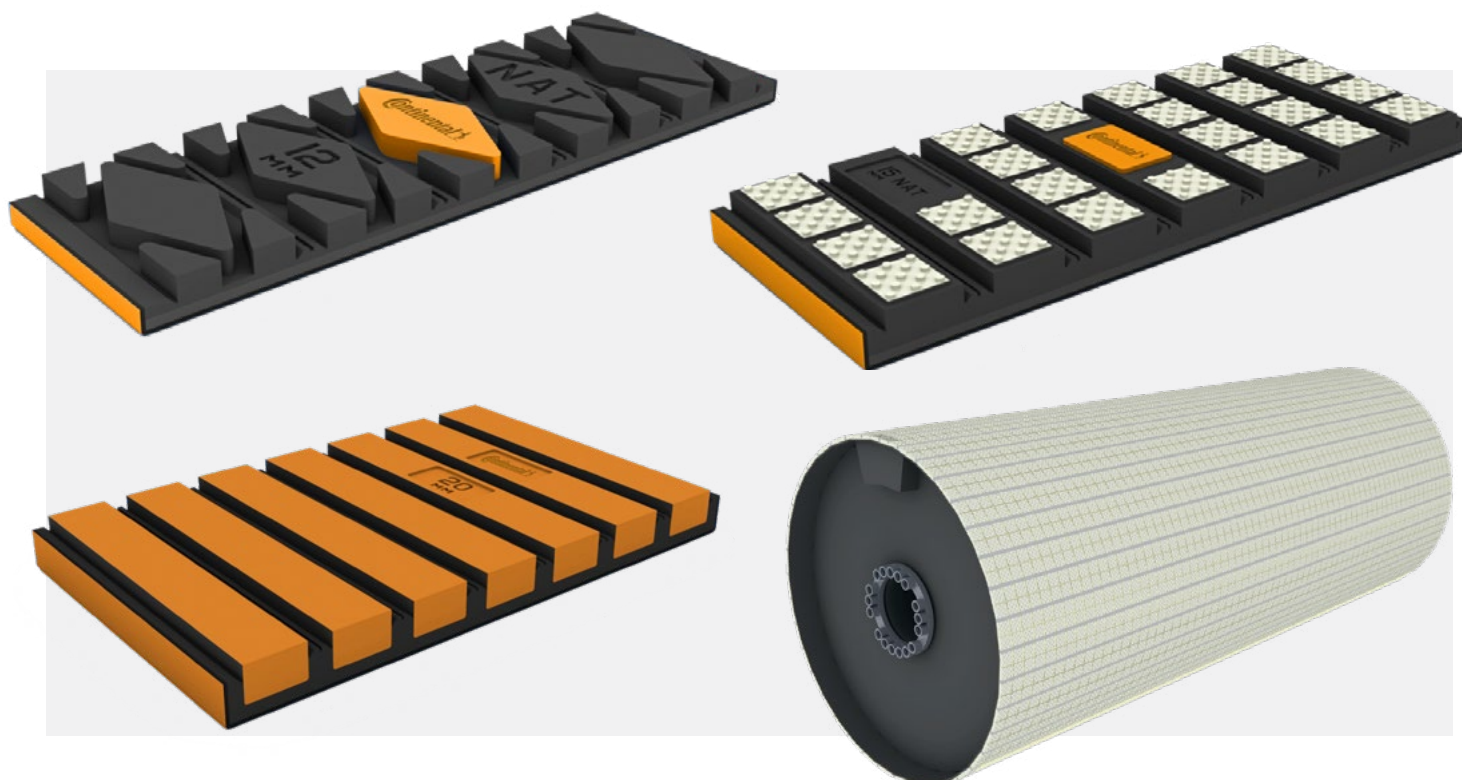

Digital Solutions

Continental conveyor belt solutions help to protect your investment, maximize efficiencies and prevent workflow interruption. We offer a wide range of monitoring systems, services and software to take your efficiency to the next level. With online damage detection systems, on-demand condition scanning services and an asset management software, Continental supplies you with important data to help keep your operation up and running.

Conveyor Condition Monitoring Software

Connection to our service platform CONTI+

- > Mobile and Web App
 - > Easy Organization
 - > Master Data Management
 - > Access current and historical conveyor data
 - > Download reports on your conveyor belt assets
 - > Predict or estimate remaining belt life
 - > Upload pictures or reports
 - > Generate savings reports
- Select the right modules for your needs
- > Basics
 - > Inspection
 - > Engineering
 - > IoT
- The Smartest way to monitor your conveyors!

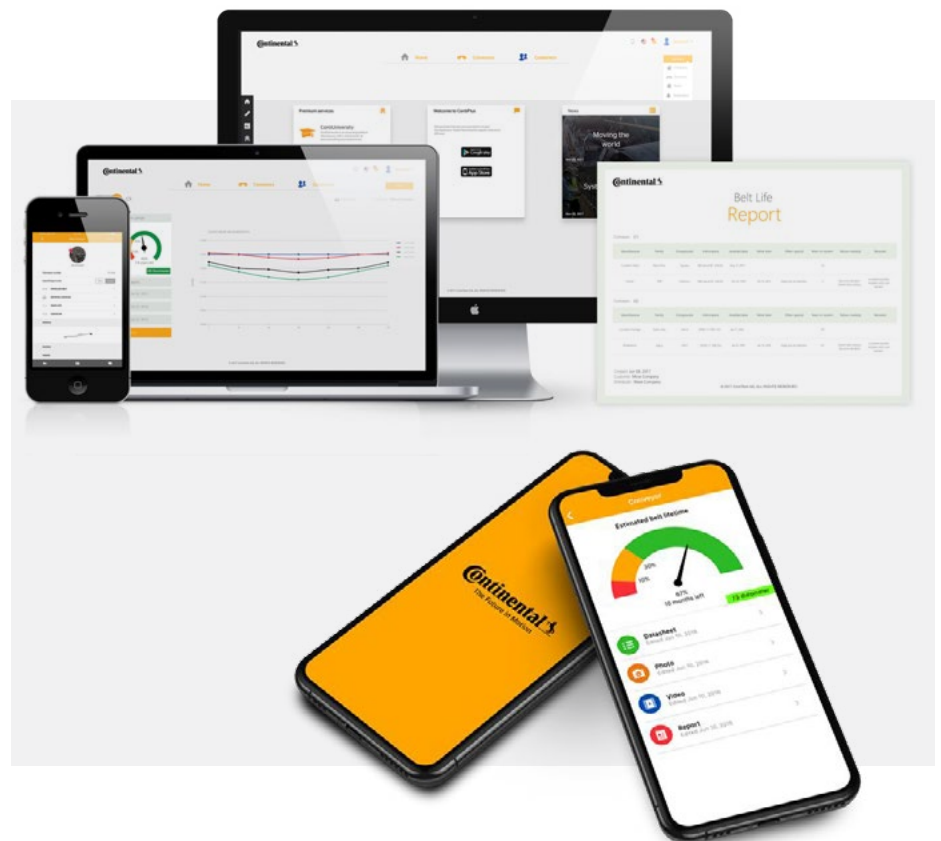

Belt Monitoring Systems

Continental Conveyor Belt Monitoring Systems generate an overall picture of conveyor belt health.

Our reliable belt monitoring tools can easily be adjusted to accommodate the typical changes that occur over the life of a conveyor belt. Easy to interpret belt condition reports are objectively generated by Continental's monitoring software.

- > Best-in-class sensor technology
- > Reliability and high quality data output
- > User-friendly graphical interfaces
- > Easy to understand on-demand reports
- > On-site or remote online technical assistance utilizing global experts

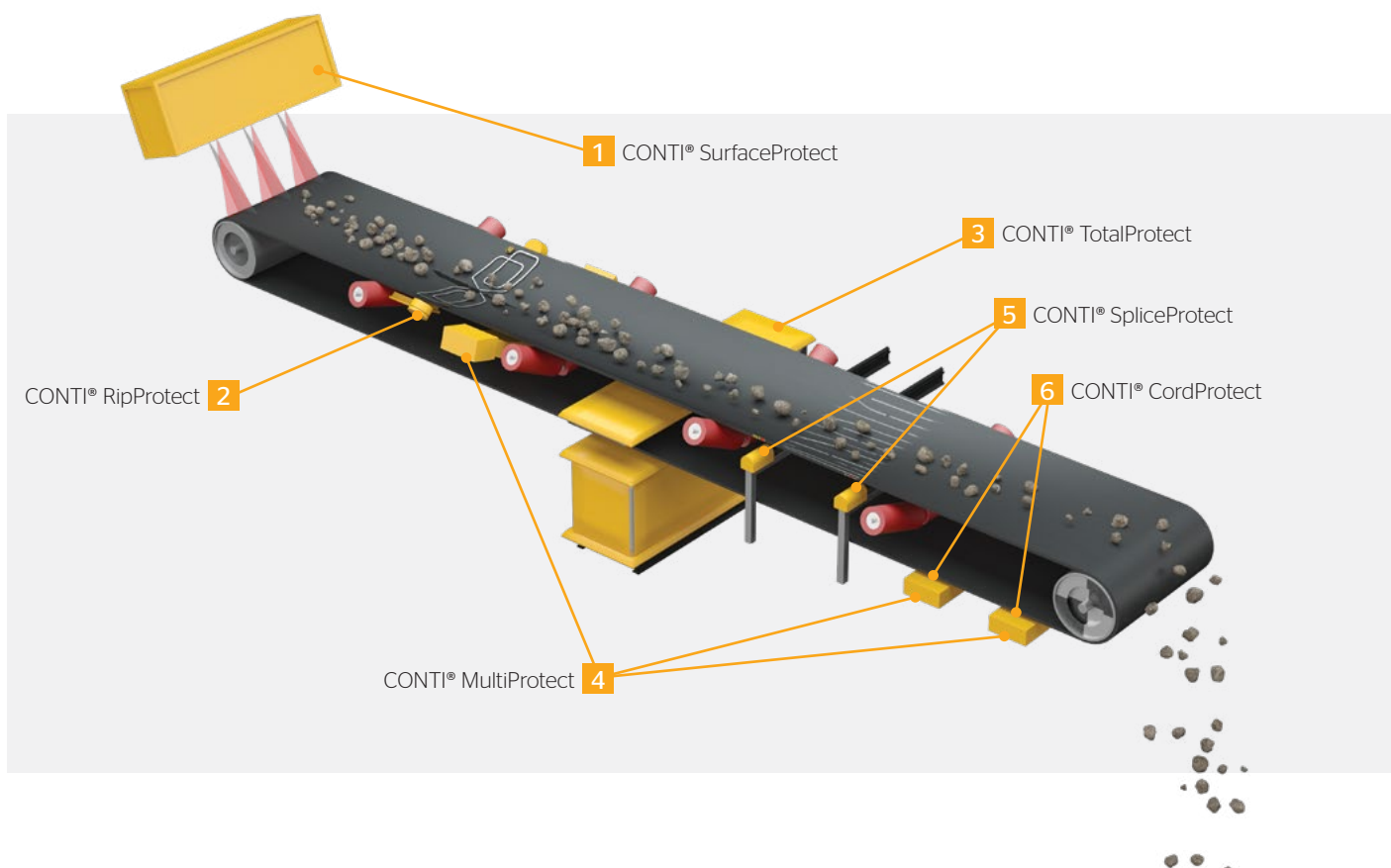

Service Engineering

Service Engineering

- > Major Belt Installation & Replacement Projects
- > Equipment Design & Build (inc. Mechanical & Electrical Systems)
- > Engineering design, analysis & reporting
- > Technical Support for our Service Branches & Teams
- > Research & Development of service-related tooling & equipment systems
- > Development of formal documentation packages (i.e. work methodologies, SWI's, operating procedures, etc).



Field Services

Field Services

- > Belt installation & replacement
- > Belt splicing
- > Conveyor maintenance & repair
- > Maintenance contracts
- > Conveyor emergency call outs



Contact Us

Continental
Australian Headquarters
7 Dunlop Court
Bayswater, VIC 3153 AUS

Australia / New Zealand

p: +61 (3) 9721 0600 e: ausep@continental.com

www.continental-industry.com

APAC Locations

 **Australia**
7 Dunlop Crt,
Bayswater VIC 3153 Australia

 **China**
20F Building A, North American Plaza, 518 Kunming Road,
Shanghai 200082 P.R. China

 **India**
Ideal Plaza, 4th Floor, 11/1, Sarat Bose Road,
Kolkata-700 020.

 **Singapore**
80 Boon Keng Road,
Singapore 339780

APAC Service Branches

 **Karratha (WA, Australia)**
40 Exploration Drive, Gap Ridge (Karratha) WA 6714
p: +61 8 9186 0500 e: waservices.au@continental.com

 **Mackay (QLD, Australia)**
45 Gateway Drive, Paget QLD 4740
p: +61 7 4841 9800 e: qldservices.au@continental.com

 **Newcastle (NSW, Australia)**
10/19 Balook Dr, Berfield NSW 2322
p: +61 2 4966 3493 e: aus.ep@continental.com

 **Perth (WA, Australia)**
50 Triumph Ave, Wangara WA 6065
p: +61 8 6240 3500 e: waservices.au@continental.com

 **China**
Building 1, No. 1333 Xinda Road, Qingpu Industrial Park,
201700 **Shanghai**, P.R.China
p: +86 21 6921 4910

 **India**
R.P.O. Muragacha Road, Gayeshpur, **Kalyani**
District: Nadia, West Bengal: 741234
p: +91 33 66327878, +91 9748960520